

NDAA EYE-SIGHT

The new Eye-Sight series serves security professionals seeking a professional line featuring outstanding image quality, full connectivity, and enhanced video analytics functions based on Artificial Intelligence.



DAI-340IPEN-MVF-V4

40M IR 4MP DDA ANALYTICS MOTORIZED LENS DOME/TURRET ANTI-VANDAL CAMERA WITH BUILT-IN CHECK POINT PROTECTION AND DUAL SYSTEM TECHNOLOGY

Equipped with a 2.8-12mm motorized lens, this 4MP anti-vandal camera is designed for medium-distance surveillance (up to 40m) in indoor and outdoor scenarios. Intended for high-security area monitoring (such as banks, hotels, or chain stores) and to capture crime in the act, the DAI-340IPEN-MVF-V4 features vandal-proof IK10 protection, which makes it extremely hard to sabotage. Fitted with the new "Dual System" technology, the camera can deal with internal anomalies independently, making it more redundant to software-based issues. The camera offers broad possibilities for Analytics, from Face Detection to the outstanding DDA Analytics (Detect, Distinguish, Alert) and the newly developed DDA2, which can perform object recognition, object counting, and investigate specifics such as age, color, gender, vehicle brand and much more. The DAI-340IPEN-MVF-V4 camera is here to end false alarms and, with the Check Point protection, ensures that your devices are cyber-protected round the clock.

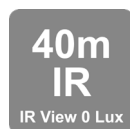

MAIN FEATURES

- 4MP
- EYE-SIGHT
- 2592×1520 Resolution
- 2.8-12mm Motorized Vari-Focal (98°-28°)
- 3D-DNR
- IP67, Ik10
- DDA Analytics
- 2-Way Audio
- Alarm in + Out

ANALYTICS

- General Analytics: Camera Tampering
- AI: (Object Recognition): Humans, 2/4 wheel vehicles
DDA Sterile Area
DDA Line Crossing
DDA Object Counting
- AI: (Face Detection): 10 Faces per frame
- AI: Heatmap
- DDA2: Advance Object Classification



SPECIFICATIONS

Image Sensor	1/3" CMOS (16:9)
Effective Pixels	2592X1520
Electronic Shutter	1/2s ~ 1/100000s
Frame Rate	1-25/30FPS in Normal Mode. 1-50/60FPS in HFR Mode***
Day & Night	ICR
Min. Illumination	Day: 0.1lux / Night: 0.005lux (@F1.6, AGC on) 0lux with IR on
Audio compression	G.711A/G.711U
Communication	2-Way Audio
Image Settings	AWB, AGC Adjustable, Exposure Mode (Auto) Sharpness, Saturation, Brightness & Contrast Adjustable
Image Enhancement	True WDR (120dB), BLC, HLC, ROI
Noise Reduction	3D-DNR
Image Orientation	Mirror/Flip
Privacy Zone	Yes
Motion Detection	Yes
Analytics	General Analytics: Camera Tampering AI (Object Recognition): DDA Sterile Area, DDA Line Crossing, DDA Object Counting AI (Face Detection): 10 Faces per frame AI: Heatmap DDA2: Advance Object Classification
Video Compression	H.265S/H.264S*, H.265+/H.264+/H.265/H.264/MJPEG**
Resolution	4MP (2592x1520) / 3MP (2304x1296) / 2MP (1920x1080) / D1 / QVGA /CIF
Multi-Stream	Master Stream: 4MP(2592x1520) / 2K (2560x1440) / 3MP / 2MP / 1MP Substream: 1MP/QVGA/D1/CIF Third Stream: QVGA/D1/CIF (1~30fps)
Bit rate	64Kbps ~ 7Mbps@H.265 / 64Kbps ~ 8Mbps@H.264
Encode Mode	VBR/CBR
Image Quality	Five levels under VBR; Free adjustment under CBR
IR Distance	40m (2 High-Power IR LED)
Lens (Field of View)	2.8-12mm MVF with Auto Focus (98°-28°)

*Mainstream only, **Substream only, ***1080p, no true-WDR

SPECIFICATIONS

Iris	DC Iris
Lens Mount	Ø14 Mount
Protection Rate	Water Proof: IP67, Vandal Proof: IK10
Bracket	3-Axis Bracket
Dimensions	Ø140.9x100.3mm
Weight (gross)	~950g
Network	RJ45 (+PoE)
Power	DC Socket
Analog Video Output	CVBS out + Technician Port
Audio Connectivity	Built-in Microphone + Audio Input + Audio Output
SD Card	Event/Schedule based Main/Substream recording (Up to 256Gb)
Hard Reset Button	Yes
Alarm	Alarm in + Alarm out
Remote Monitoring	IE Browsing, VMS Software, Provision Cam2 Mobile App
User Access	Supports simultaneous monitoring of up to 10 users with multi-stream real-time transmission
Network Protocol	IPv4, IPv6, TCP, UDP, DHCP, NTP, DDNS, 802.1X, RTSP, Multicast, UPnP, Email, FTP, HTTPS, QoS, P2P
ONVIF	Yes
Ethernet	100Mbps
PoE	Yes
Power Supply	DC12V/~600mA / PoE/~9W
Work Environment	-30°C~60°C, 10%~90% Humidity
Junction Box	PR-JB14IP66

DIMENSIONS

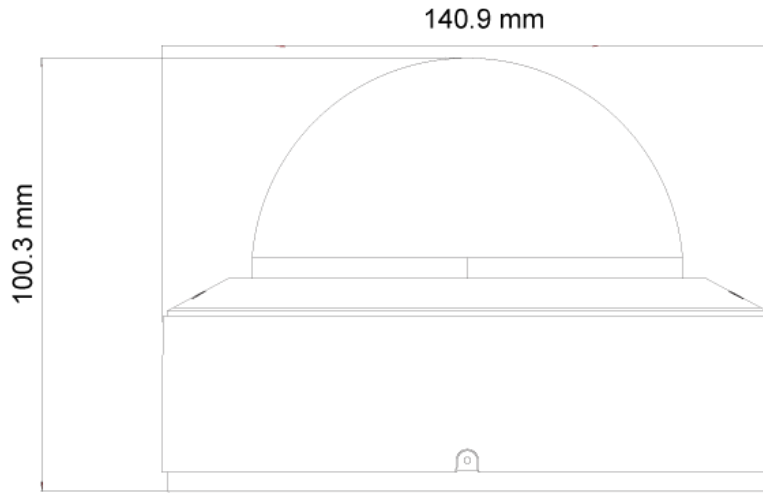

ACCESSORIES

